

P 210 BK

PALFINGER



The flexible platform with motion in mind

Jib artistry at the highest level

Uniquely flexible and suitable for a wide range of tasks. That's the new P 210 BK. This access platform with a working height of 21 meters, the largest outreach of its type and a jib rotation of 185 degrees sets new standards in the 3.5 t class.

Its flexibility makes it an ideal machine for hire business and for the municipal sector. The jib rotation of 185° allows to implement a special operation mode for driving the vehicle with an upright jib and even ensures accessibility over, under or through obstacles for optimum workflow. Working below ground level is also possible.



Best performance in the 3.5 t class

First-class performance

"7.5 t performance on a total weight of 3.5 t". High torsional rigidity with a low dead weight are the result of a successful design concept by PALFINGER.

- Telescopic extension booms of weight-optimized hexagonal aluminum sections
- Maintenance-free sliding elements for wear-resistant telescope guidance



Comfort

- Self-explanatory operator prompting at the control panel
 - Error indication via LED
- Rugged, protective synthetic cover



- Sturdy aluminum workman basket with integrated tool shelf
- PALFINGER safety concept: self-closing basket door for easy, upright access,
 - additional handrail and non-slip floor
 - Electronic leveling system
 - Basket swiveling range 2 x 85°



- Jib of weight-optimized aluminum construction
 - Maximum performance: rotatable up to 185°!
- Special platform mode driving and operating while jib in an upright position and the ability to work below ground level



Safety

- Patented outreach optimization (outreach regulation as a function of setup inclination up to 5°)
 - Generously dimensioned stabilizer plates
- 3 stabilizer modes (full, one-sided, within vehicle dimensions)
 - Underrun protection in acc. with 2006/20/EC as standard



Available by Nissan, Renault, Mercedes, VW and Iveco-chassis.

What an amazing performance for a 3.5 t unit!

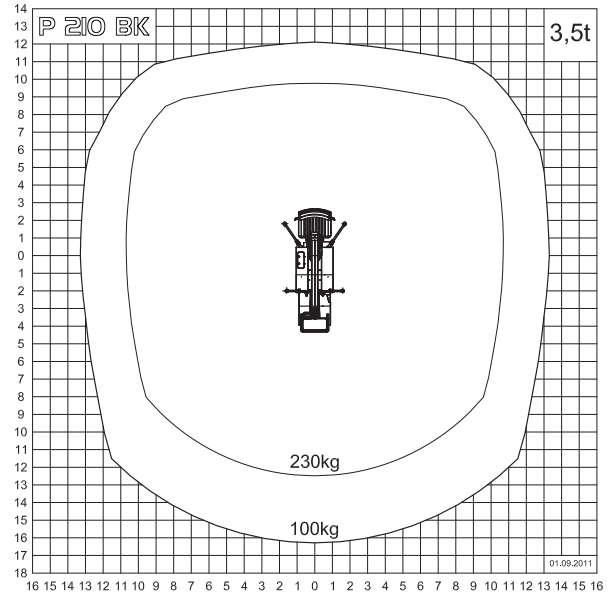
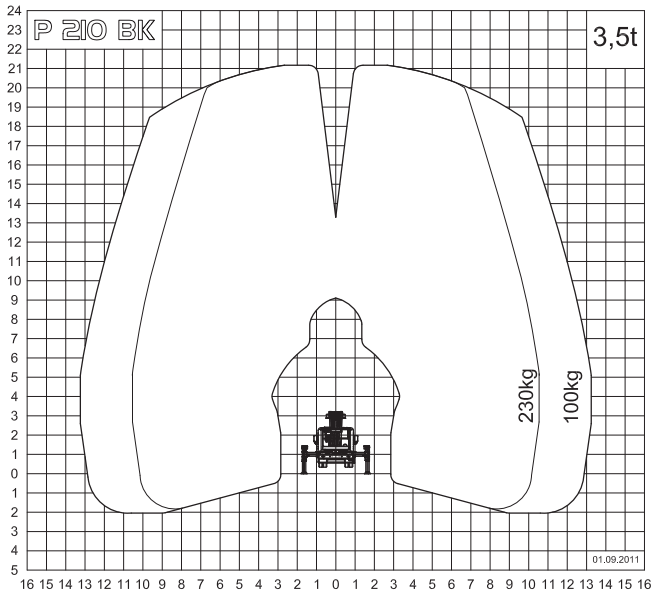

Technical Data P 210 BK

Max. working height	21 m
Max. cage bottom height	19 m
Max. outreach to the side (incl. hand area)	13.3 m
Max. outreach to the back (incl. hand area)	16.3 m
Angle of main boom	-15° - 84°
Rotation angle of turntable	500°
Rotation angle of cage	2 x 85°
Rotation angle of cage boom	185°
Max. cage load	230 kg
Size of cage	1.4 x 0.7 x 1.1 m
Max. inclination of platform	5°
Height in transportposition	2.90 m

Width in transportposition	2.22 m
Overall length	6.90 m
Wheelbase	2.90 m
Overall weight with persons in the cab	3320 kg

Serial equipment

Automated outriggers and setup leveling	yes
Check for battery voltage	yes
Memory-Function	yes
Home-Function	yes

