

2013 Series

LIGHTLIFT 20.10

PERFORMANCE III S

Hinowa®

HIGH PERFORMANCE
AND COMPACT
TRACKED AERIAL
PLATFORM



230 kg capacity!

www.hinowa.com

DISTINCTIVE FEATURES

- 230 kg capacity for the whole working area
- Wide working diagram: 20 m working height and 9.7 m continuous outreach with flush with the wall trajectory
- Wide range of motorizations available
- Speed and precision of the movements



PERFORMANCE III

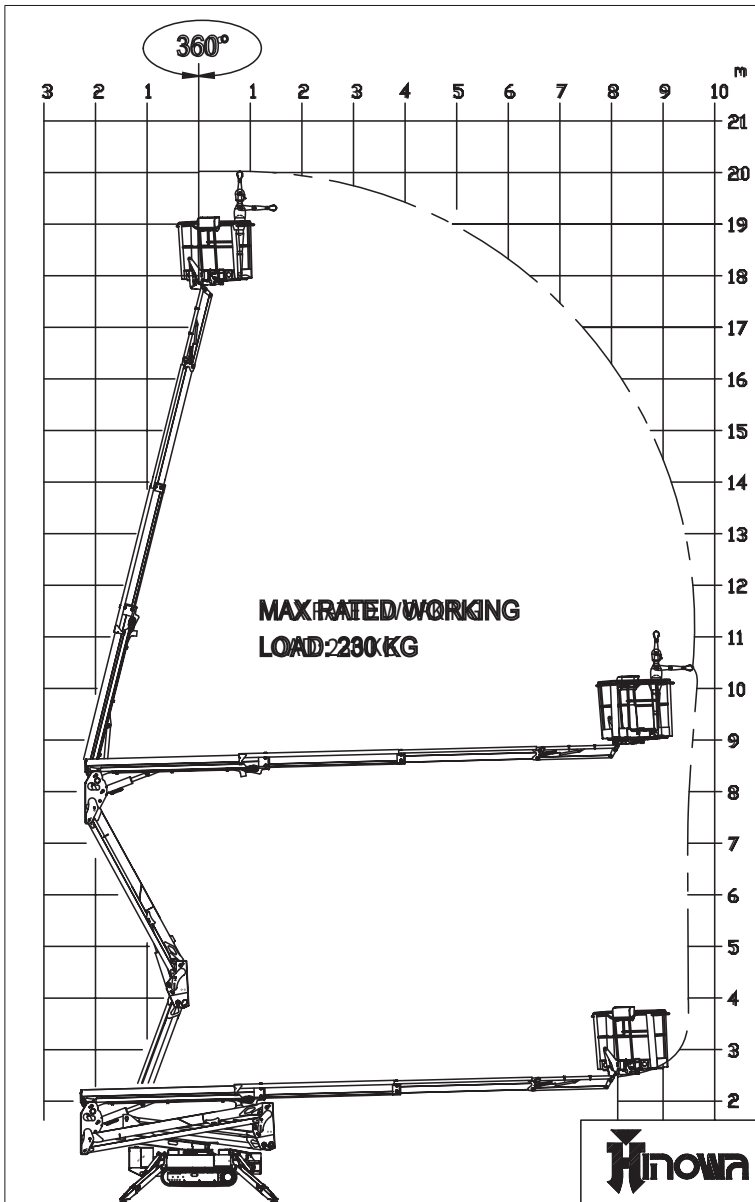

 **CAPACITY**
230 kg

MAX WORKING HEIGHT  20,10 m

MAX HORIZONTAL WORKING OUTREACH  9,70 m

TRANSPORT LENGTH  5,01 m

TRANSPORT LENGTH WITHOUT BASKET AND ROTATED SUPPORT  4,50 m

TRANSPORT HEIGHT  1,99 m

STANDARD CAGE DIMENSIONS  1335x690xh.1100 mm

WEIGHT WITHOUT FUELS AND OIL  2800 kg (with petrol engine)

TOTAL OPERATING WEIGHT  2880 kg (with petrol engine)

THERMIC ENGINE AVAILABLE 

- Honda iGX440-12,7HP 3600 rpm
- Perkins 402.05-14HP 3600 rpm

ELECTRIC MOTOR  2,2kw-230V-50Hz (110 optional) 1500rpm

CLOSED MACHINE WIDTH  795 / 1095 mm



ELECTRIC MOTOR WITH LITHIUM BATTERIES

OPTIONAL 90Ah / 72V

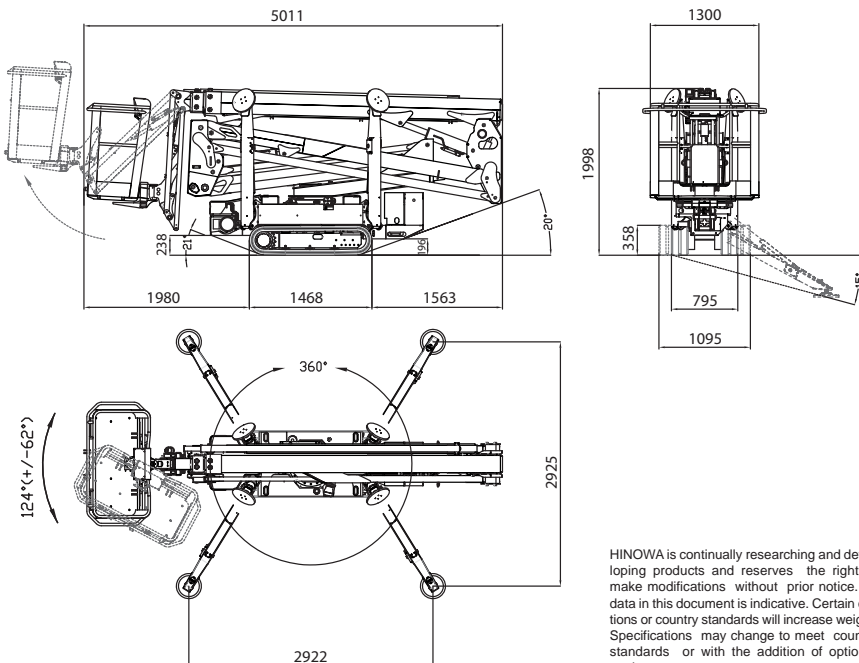

HINOWA is continually researching and developing products and reserves the right to make modifications without prior notice. All data in this document is indicative. Certain options or country standards will increase weight. Specifications may change to meet country standards or with the addition of optional equipment.



HINOWA SPA

Via Fontana • 37054 NOGARA • Verona • Italy

Tel. +39 0442 539100 • Fax +39 0442 539075

info@hinowa.com

www.hinowa.com